

AGENDA
Parks & Recreation Commission
Wednesday, May 22, 2024
7:00 PM
Mitchell Amphitheater

Call to order:

Roll call:

Approval of agenda: May 22, 2024

Approval of minutes: April 24, 2024

Public comments:

Old Business Report from City Liaison:

New Business:

- Fitness Course updates from Commissioners
- Soccer Field Sidewalks
 - Master Plan Goal 5.2, 5.3
- Potential Eagle Scout Projects
 - Master Plan Goal 7.1
- Amphitheater Mural
 - Master Plan Goal 5.1, 5.3, 5.9

Next Meeting: June 26, 2024

Public/Commissioners Comments:

Adjournment:

The City of Owosso will provide necessary reasonable auxiliary aids and services, such as signers for the hearing impaired and audiotapes of printed materials being considered at the meeting, to individuals with disabilities at the meeting/hearing upon seventy-two (72) hours' notice to the City of Owosso. Individuals with disabilities requiring auxiliary aids or services should contact the City of Owosso by writing or calling the following: Amy K. Kirkland, City Clerk, 301 W. Main St, Owosso, MI 48867 or at (989) 725-0500. The City of Owosso website is: www.ci.owosso.mi.us

**PARKS AND RECREATION COMMISSION
REGULAR MEETING**

Draft Minutes of Wednesday, April 24, 2024
7:00 p.m. at City Hall

- CALL TO ORDER:** Commissioner Workman called the meeting to order at 7:03 p.m.
- PLEDGE OF ALLEGIANCE:** Was recited
- ROLL CALL:** Was taken by Amy Fuller
MEMBERS PRESENT: Chairman Workman, Vice Chair Selbig (7:12), Commissioners Maginity, Rodman, and Smith.
MEMBERS ABSENT: Commissioners Mahoney and Bila
- APPROVAL OF AGENDA:** COMMISSIONER MAGINITY MADE A MOTION TO APPROVE THE AGENDA FOR APRIL 24, 2024. MOTION SUPPORTED BY COMMISSIONER SMITH. AYES ALL, MOTION CARRIED.
- APPROVAL OF MINUTES:** COMMISSIONER RODMAN MADE A MOTION TO APPROVE THE MINUTES FOR FEBRUARY 28, 2024 WITHOUT CHANGES. MOTION SUPPORTED BY COMMISSIONER MAGINITY. AYES ALL, MOTION CARRIED.

PUBLIC COMMENTS:

Steven Shannon spoke to the Commission about the bike trails at Rosevear Park.

OLD BUSINESS REPORT:

Amy Fuller shared updates on the city's budget process, stated that 7 trees would be planted at the soccer fields, reminded the Commission about the Park Cleanup scheduled for April 27, and detailed two grants she was working on for projects the Commission has been trying to complete (one for Grand Ave. Park and one for the soccer fields).

ITEM OF BUSINESS:

Amphitheater Mural: The Commission discussed design ideas for the amphitheater mural. They asked questions of artist Andrew Reider. They told him they would like to see some renderings with a nature theme centered around the Shiawassee River. Commissioner Smith stated she didn't think it should be so bold that it would take away from the performers. Commissioner Maginity suggested that the space seemed very tall and the design could make the space feel shorter.

Bylaws: The Commissioner reviewed their bylaws. No changes were suggested.

Next Meeting: May 22, 2024, at 7:00 PM at the Mitchell Amphitheater

Commissioner Smith made a motion to hold the next meeting at the amphitheater. Motion supported by Commissioner Rodman. Ayes, all. Motion carried.

PUBLIC/COMMISSIONERS COMMENTS: None.

ADJOURNMENT: COMMISSIONER SMITH MADE A MOTION TO ADJOURN AT 7:50 P.M. MOTION SUPPORTED BY COMMISSIONER RODMAN. AYES ALL, MOTION CARRIED.

Respectfully submitted by:
Amy Fuller, Assistant City Manager



May 17, 2024

Parks and Recreation Commission
Ongoing Project List

Park Clean Up: The park clean up went very well. It was a beautiful day and participation was great. Thanks to everyone who helped, especially Foster Coffee, the Mayor, City Manager, the pickleball group and the Nazarene Church Youth Group.

Water at Collamer Park: DPW will finish this month.

Harmon Patridge Curwood Sign: Commissioner Smith will stain the sign this spring/summer.

Fitness Course: stations and signage will need to be selected by the Commission.

Hugh Parker Field Trees: DPW planted 7 trees with the millage funds set aside for tree planting. The Owosso Rotary Club will fund 5 more trees to be planted this fall.

Hugh Parker Concessions Building: DPW repaired the electric hand dryers and replaced the roof.

Curwood Grant: A draft design for the amphitheater mural has been provided by the artist and is an item on the agenda.

Hugh Parker Sidewalk Improvements: The \$10,000 requested by the Commission has been included in the 2024-25 budget which is pending city council approval. City staff have located a \$200,000 grant program that could allow us to expand this project and is included as an agenda item.

CIS Trail: Engineering for this project has begun. We are expecting construction to take place in two phases, beginning in 2025.

Grand Avenue Park: Staff has been notified the city will be awarded \$15,000 from the NEP grant and \$15,000 from the general fund (pending council approval), to be matched with \$13,000 allocated by the commission from millage funds for this park project. Staff sent letters to homes in this neighborhood seeking feedback on the project.

Respectfully submitted,

Amy Fuller
Assistant City Manager

HUGH PARKER SOCCER COMPLEX SIDEWALK INSTALLATION

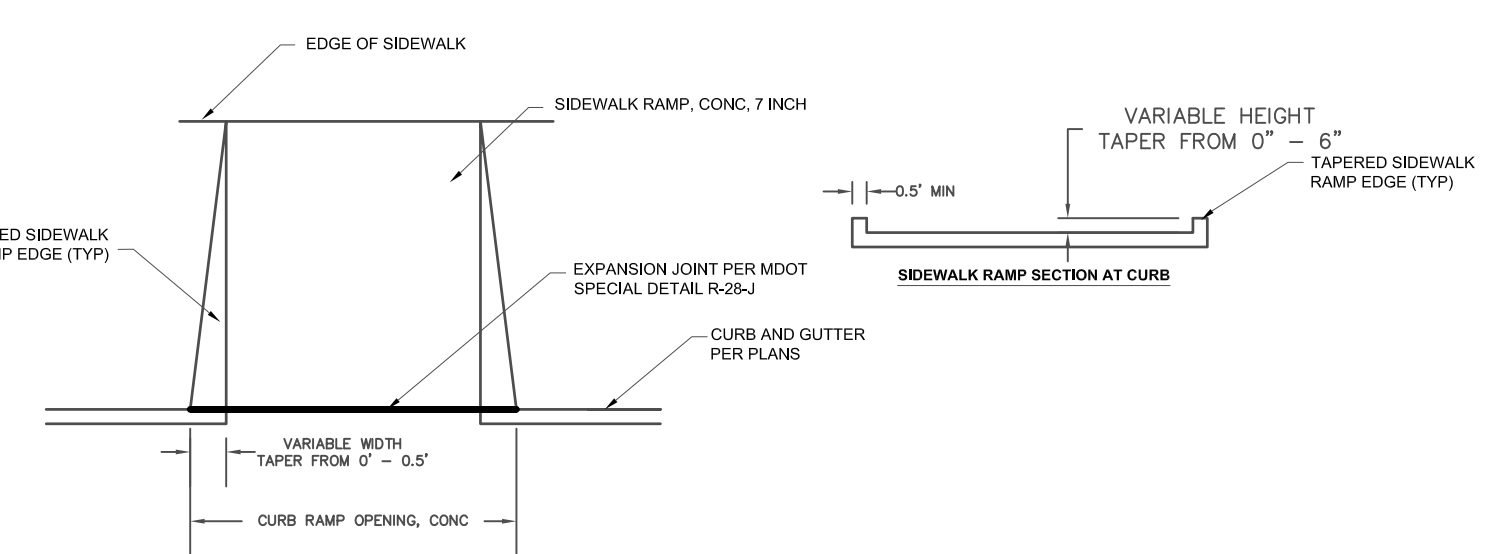
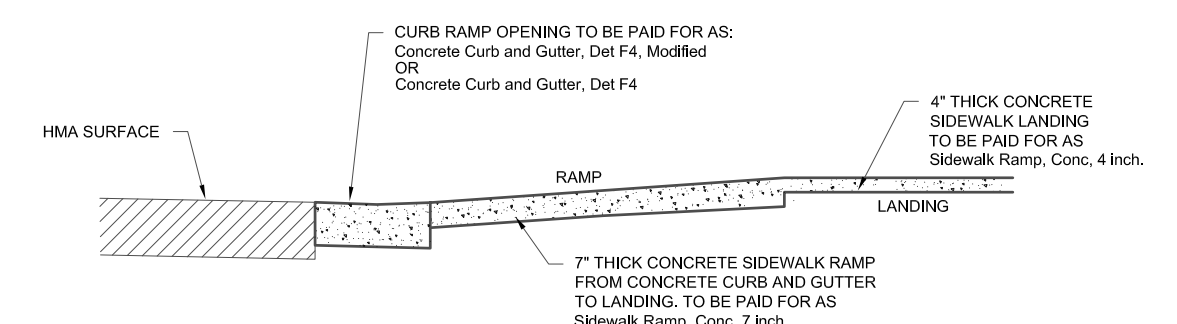
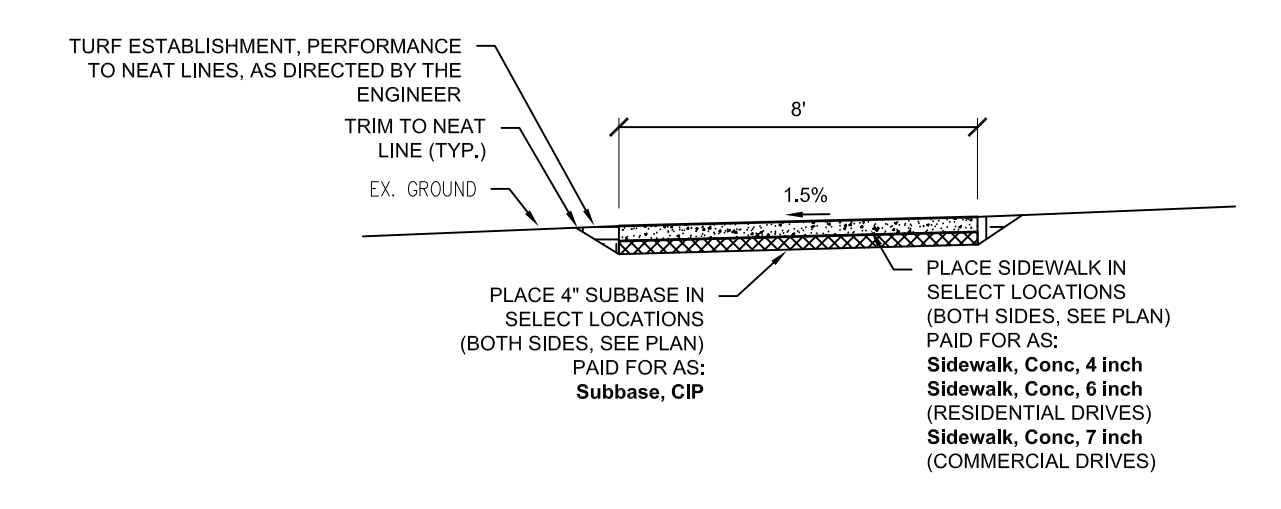
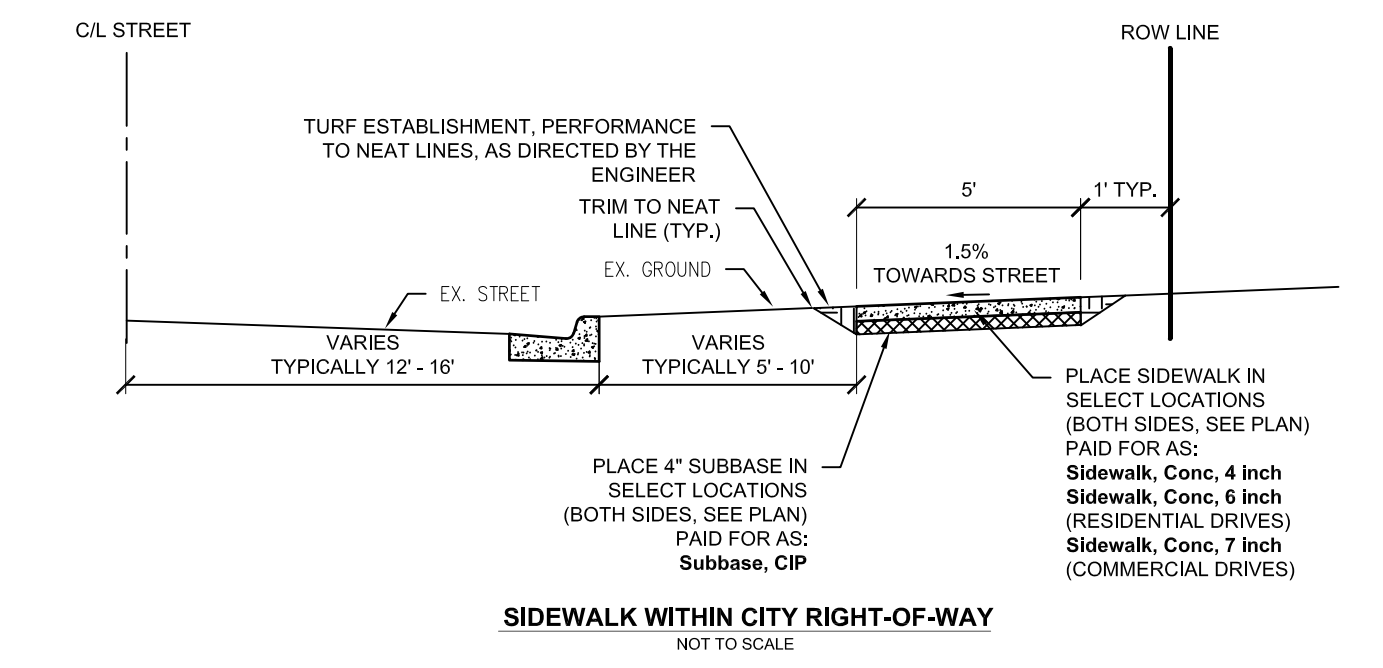
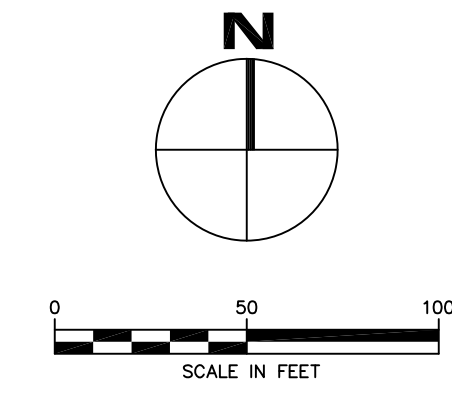

| CONSTRUCTION QUANTITIES | | |
|-------------------------|------|---|
| QUANTITY | UNIT | WORK ITEM |
| 30 | Syd | Pavt, Rem |
| 500 | Cyd | Excavation, Earth |
| 3 | Ea | Erosion Control, Inlet Protection, Fabric Drop |
| 1300 | Ft | Erosion Control, Silt Fence |
| 150 | Cyd | Subbase, CIP |
| 25 | Ton | Hand Patching |
| 60 | Syd | Conc Pavt, Misc, Nonrein, 7 inch |
| 100 | Syd | Driveway, Nonrein Conc, 7 inch |
| 150 | Ft | Curb and Gutter, Conc, Det F4 |
| 20 | Ft | Detectable Warning Surface, Modified |
| 15 | Ft | Curb Ramp Opening, Conc |
| 11500 | Sft | Sidewalk, Conc, 4 inch |
| 1200 | Sft | Sidewalk, Cocon, 7 inch |
| 250 | Sft | Curb Ramp, Conc, 7 inch |
| 1 | Ea | Fence Gate, 8 ft, for 72 inch Chain Link Fence |
| 3 | Sft | Sign, Type III-B |
| 15 | Ft | Post, Steel, 3 pound |
| 120 | Ft | Pavt Mrkg, Waterborne, 12 inch, Cross Hatch, Blue |
| 80 | Ft | Pavt Mrkg, Waterborne, 4 inch, Blue |
| 1500 | Syd | Turf Establishment, Performance |

CITY OF OWOSSO, MICHIGAN
ENGINEERING DIVISION
DEPT. OF PUBLIC SERVICE

| NO. | DATE | BY | REVISIONS | APPROVED BY |
|-----|---------|----|-------------------------|---------------|
| 1 | 4/25/24 | CW | GRANT APPLICATION PLANS | ORIGINAL PLAN |

| BENCH MARK DATA | DESCRIPTION | ELEV. |
|-----------------|-------------|-------|
| | | |

CITY OF OWOSSO - SHARED STREETS & SPACES GRANT
PROGRAM APPLICATION - HUGH PARKER SOCCER COMPLEX

MAY 2024
PROJECT NO.
FIELD BOOK
PG.



05/17/2024 03:09 PM
User: AKFuller
DB: Owosso

CASH SUMMARY BY FUND FOR CITY OF OWOSSO
FROM 07/01/2023 TO 05/17/2024
FUND: 208
CASH AND INVESTMENT ACCOUNTS

| Fund | Description | Beginning Balance 07/01/2023 | Total Debits | Total Credits | Ending Balance 05/17/2024 |
|------|----------------------------|------------------------------------|-----------------|------------------|---------------------------------|
| 208 | PARK/RECREATION SITES FUND | 29,809.14 | 10,294.70 | 14,406.28 | 25,697.56 |

| GL NUMBER | DESCRIPTION | YTD BALANCE | | AVAILABLE BALANCE | % BDGT USED |
|--------------------------------|----------------------------------|---------------------------|---------------------------------|----------------------|----------------|
| | | 2023-24 AMENDED BUDGET | 05/31/2024 NORMAL (ABNORMAL) | | |
| Fund 101 - GENERAL FUND | | | | | |
| Expenditures | | | | | |
| Dept 751 - PARKS | | | | | |
| 101-751-702.200 | WAGES | 62,606.00 | 45,296.44 | 17,309.56 | 72.35 |
| 101-751-702.300 | OVERTIME | 3,500.00 | 2,754.72 | 745.28 | 78.71 |
| 101-751-702.400 | WAGES - SEASONAL | 28,000.00 | 5,437.20 | 22,562.80 | 19.42 |
| 101-751-702.800 | ACCRUED SICK LEAVE | 0.00 | 0.00 | 0.00 | 0.00 |
| 101-751-703.000 | OTHER COMPENSATION | 0.00 | 0.00 | 0.00 | 0.00 |
| 101-751-715.000 | SOCIAL SECURITY (FICA) | 7,199.00 | 4,051.23 | 3,147.77 | 56.27 |
| 101-751-716.000 | FRINGES | 0.00 | 0.00 | 0.00 | 0.00 |
| 101-751-716.100 | HEALTH INSURANCE | 26,316.00 | 12,760.91 | 13,555.09 | 48.49 |
| 101-751-716.200 | DENTAL INSURANCE | 917.00 | 631.46 | 285.54 | 68.86 |
| 101-751-716.300 | OPTICAL INSURANCE | 142.00 | 57.92 | 84.08 | 40.79 |
| 101-751-716.400 | LIFE INSURANCE | 300.00 | 207.03 | 92.97 | 69.01 |
| 101-751-716.500 | DISABILITY INSURANCE | 643.00 | 431.73 | 211.27 | 67.14 |
| 101-751-717.000 | UNEMPLOYMENT INSURANCE | 9.00 | 7.99 | 1.01 | 88.78 |
| 101-751-718.100 | MUNICIPAL EMPLOYEES RETIREMENT : | 0.00 | 0.00 | 0.00 | 0.00 |
| 101-751-718.200 | DEFINED CONTRIBUTION | 3,130.00 | 2,168.23 | 961.77 | 69.27 |
| 101-751-719.000 | WORKERS' COMPENSATION | 4,300.00 | 3,572.48 | 727.52 | 83.08 |
| 101-751-728.000 | OPERATING SUPPLIES | 5,000.00 | 4,597.67 | 402.33 | 91.95 |
| 101-751-818.000 | CONTRACTUAL SERVICES | 43,700.00 | 32,714.33 | 10,985.67 | 74.86 |
| 101-751-920.100 | ELECTRICITY | 11,488.00 | 7,785.86 | 3,702.14 | 67.77 |
| 101-751-920.200 | GAS | 0.00 | 0.00 | 0.00 | 0.00 |
| 101-751-920.300 | TELEPHONE | 0.00 | 0.00 | 0.00 | 0.00 |
| 101-751-920.400 | WATER & SEWER | 24,208.00 | 19,347.48 | 4,860.52 | 79.92 |
| 101-751-920.500 | REFUSE | 300.00 | 465.74 | (165.74) | 155.25 |
| 101-751-930.000 | BUILDING MAINTENANCE | 5,000.00 | 5,531.31 | (531.31) | 110.63 |
| 101-751-930.200 | BLDG MAINTENANCE-BALLFIELDS | 10,000.00 | 8,718.24 | 1,281.76 | 87.18 |
| 101-751-937.000 | TREES & GARDEN | 1,000.00 | 262.43 | 737.57 | 26.24 |
| 101-751-940.000 | EQUIPMENT RENTAL | 100,000.00 | 95,196.67 | 4,803.33 | 95.20 |
| 101-751-971.000 | LAND | 0.00 | 0.00 | 0.00 | 0.00 |
| 101-751-974.000 | LAND IMPROVEMENTS | 92,000.00 | 10,375.75 | 81,624.25 | 11.28 |
| Total Dept 751 - PARKS | | 429,758.00 | 262,372.82 | 167,385.18 | 61.05 |
| TOTAL EXPENDITURES | | 429,758.00 | 262,372.82 | 167,385.18 | 61.05 |
| Fund 101 - GENERAL FUND: | | | | | |
| TOTAL REVENUES | | 0.00 | 0.00 | 0.00 | 0.00 |
| TOTAL EXPENDITURES | | 429,758.00 | 262,372.82 | 167,385.18 | 61.05 |
| NET OF REVENUES & EXPENDITURES | | (429,758.00) | (262,372.82) | (167,385.18) | 61.05 |